



**OLIVARI** 

Maniglie per l'architettura  
Door handles for architecture



**OLIVARI** 

dal 1911  
maniglie  
made  
in Italy

Dal 1911 Olivari realizza maniglie in Italia,  
all'interno dei propri stabilimenti,  
dove si svolge l'intero ciclo produttivo.  
Partendo da barre in ottone, le maniglie vengono  
stampate, lavorate, smerigliate, lucidate,  
cromate e marchiate al laser.

Olivari ha ottenuto le certificazioni  
ISO 9001 e ISO 14001  
e si avvale delle tecnologie più evolute,  
ma ha mantenuto tutta la sapienza artigianale  
accumulata in cento anni di storia.

Since 1911 Olivari has been manufacturing handles  
at its own factories in Italy

where the entire production process takes place.  
Starting with brass billets, the handles are forged,  
milled, polished, buffed, chrome-plated  
and hallmarked with a laser.

Olivari has attained ISO 9001  
and ISO 14001 certifications.

Though it uses the most advanced technology,  
Olivari preserves all the artisanal wisdom  
it has accumulated in 100 years of history.

**OLIVARI** 



# Fare bene, fare insieme

In Olivari il lavoro è un patrimonio aziendale, che richiede il rispetto di standard elevati ma garantisce il riconoscimento dei meriti e delle capacità di ciascuno.

In Olivari, il venerdì pomeriggio, l'ultima ora dell'ultimo turno è sempre dedicata alla pulizia e al riordino della postazione di ciascuno. Non c'è stata una disposizione dall'alto, un ordine di servizio che abbia imposto una corvée di pulizie straordinaria; è una consuetudine che si è andata consolidando negli anni, un modo per iniziare nell'ordine e nel pulito la nuova settimana ma, soprattutto, il segno di un condiviso sentimento di appartenenza, un gesto di attenzione e di cura che racconta più di tante parole come l'azienda sia anche la casa di tutti.

Bellezza ed eleganza che riaffiorano nei gesti precisi di chi ogni giorno stende con esattezza un invisibile strato di colla o di chi ripone ogni nuovo prodotto nel suo imballaggio finale, da cui uscirà fresco, pulito, fragrante. Oggetti che spesso portano la firma di un nome importante, un architetto famoso, un designer di successo, ma oggetti che nascono dalle attenzioni quotidiane di tanti. A partire dall'esperienza dei responsabili del prodotto e della produzione, che sin dai primi studi collaborano per risolvere i problemi e inventare le migliori risposte.

Ecco, in Olivari il lavoro è un autentico patrimonio d'azienda, non ricambiato da un bonario paternalismo, ma fondato su di un solido rispetto reciproco, basato sull'alto standard richiesto così come sul riconoscimento dei valori e delle capacità di ognuno.

Pensateci la prossima volta che prenderete per mano una maniglia Olivari.

# Things well-done are done together

At Olivari, labour is a company asset that implies maintaining elevated fabrication standards. It also signifies recognition of the merits and capabilities of each person.

On Friday afternoons at Olivari, the last hour of the shift is always dedicated to cleaning and reorganising each person's workstation. There have been no instructions from higher up to do so; no service order was emitted for a scheduled cleaning duty. It is a habit that grew over the years, a way to begin the new week in neat, clean conditions. Above all, it is the sign of a shared sentiment of belonging, a gesture of consideration and care that eloquently describes how the company is everybody's second home.

Beauty and elegance issue daily from the skilled hands of those who meticulously apply invisible layers of glue, those who deftly wrap each new product in its final packaging from which it will emerge fresh, unblemished and fragrant. These objects often carry the name of an important person, a famous architect or successful designer, but they are born from the concerted attention lavished on them by many, day after day. It begins with experienced product and production managers who collaborate from the very first studies to solve problems and invent the best answers.

So here we have it: at Olivari, labour is a true company asset that is not given in exchange for benign paternalism, but founded on solid reciprocal respect, based on the high standard of work that is required, and on the recognition of the merits and capacities of each person.

This is something to think about next time you take by the hand an Olivari door handle.

## 1911-1960

Nei suoi cento e più anni di storia, Olivari si è distinta per la qualità dei prodotti e per la reputazione del marchio. Di generazione in generazione la famiglia Olivari ha tramandato l'attenzione per i dettagli, la ricerca dell'innovazione e soprattutto la passione per il lavoro ben fatto.

Nel 1911 Battista Olivari fonda l'azienda a Borgomanero, in provincia di Novara, dove ancora oggi si trovano gli stabilimenti.

Nel 1926 la moglie, Antonietta Ramelli gli succede, prendendo in mano le redini dell'azienda. È una delle prime donne a capo di un'azienda in Italia: una pioniera dell'imprenditoria al femminile.

Già negli anni Trenta iniziano le prime collaborazioni con i più importanti architetti italiani del tempo: Marcello Piacentini e Gio Ponti.

Dopo la seconda guerra mondiale, l'azienda – passata nel frattempo sotto la guida dei fratelli Ernesto, Ambrogio e Luigi – contribuisce alla ricostruzione lavorando fianco a fianco con grandi maestri dell'architettura italiana: collabora con Franco Albini, Ignazio Gardella, Angelo Mangiarotti e i BBPR. Nel frattempo si approfondisce il rapporto

## 1911-1960

Throughout its 100-plus years of history, Olivari stood out for the quality of its products and the reputation of its brand. From generation to generation, the Olivari family has passed down the attention for details, the quest for innovation, and above all, the passion for working to high standards.

In 1911, Battista Olivari founded the company in Borgomanero, Novara, where the factory is still located.

In 1926, Battista's wife Antonietta Ramelli took over the helm of the business. She was one of the first women in Italy to head a company, making her a pioneer of female entrepreneurship.

In the 1930s, the company began its first collaborations with the two most important Italian architects at the time, Marcello Piacentini and Gio Ponti.

After World War II, the company, now led by the brothers Ernesto, Ambrogio and Luigi, contributed to the reconstruction, working side by side with the masters of Italian architecture: Franco Albini, Ignazio



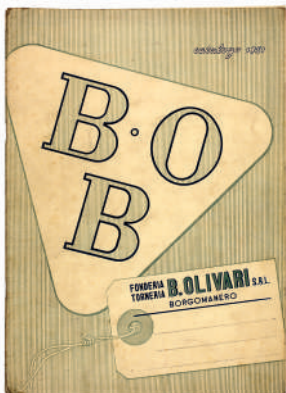
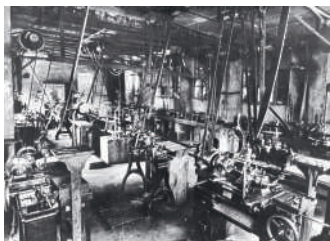

con Gio Ponti. Le maniglie, disegnate appositamente per le loro nuove architetture, oggetti pieni di invenzione e di grande eleganza, entrano stabilmente a far parte del catalogo Olivari, tanto che alcune di esse sono tuttora in produzione.

## 1960-1990

A partire dagli anni Sessanta la Olivari, sempre alla ricerca di soluzioni progettuali nuove, coinvolge i protagonisti dell'allora nascente design italiano dedicandosi a costruire nuovi solidi rapporti di collaborazione: Marcello Nizzoli, Sergio Asti, Luigi Caccia Dominioni, Joe Colombo, lo studio Monti GPA, e molti altri, entrano a far parte del catalogo Olivari. Sul fronte industriale, decide di dotarsi di una nuova unità produttiva, più ampia, e di rinnovare i macchinari di pressofusione, per rispondere alla crescita del mercato. Dalle idee visionarie, aperte al futuro, dei progettisti e dal rapporto stimolante che ne deriva, nascono maniglie innovative dal punto di vista tecnologico e formale.

Nel 1959 nacque Bica, la prima maniglia in alluminio anodizzato, e nel 1970 Boma, la prima maniglia in resina. Entrambe diventarono

Gardella, Angelo Mangiarotti and BBPR. Work relations with Gio Ponti intensified. The handles they custom, designed for their new buildings were highly elegant and inventive objects, became fixtures of the Olivari range, and some are still in production.

## 1960-1990

In the 1960s, incessantly searching for new design solutions, Olivari began working with the protagonists of the nascent Italian design scene, establishing solid relations with Marcello Nizzoli, Sergio Asti, Luigi Caccia Dominioni, Joe Colombo, Monti GPA, and many others whose handles were added to the catalogue.

On the industrial side, the company decided it needed a new, more extensive production plant with cutting-edge die-casting machinery to rise to the challenge of a growing market. The designers' visionary, futuristic ideas and the relevant stimulating work environment led to formally and technically innovative handles. Bica, the first anodised aluminium handle, came out in 1959. Boma, the first resin handle, was launched in 1970. Both rapidly became best-sellers, bolstering the design world's esteem for the company's reputation.



rapidamente dei best seller rafforzando la stima e la reputazione dell'azienda nel mondo del progetto. Negli anni Ottanta l'azienda vede progressivamente l'ingresso della terza generazione della famiglia Olivari: i fratelli Antonio, Giovanni, Giuseppe, Carlo ed Enrico offrono un'ulteriore spinta in avanti sul fronte dell'evoluzione, sia progettuale, sia tecnologica.

## 1990-2010

Gli anni Novanta sono segnati dalla proficua collaborazione con Alessandro Mendini che promuove la valorizzazione del patrimonio storico aziendale e spinge i fratelli a raccontare la storia Olivari nel libro: "L'architettura presa per mano. La maniglia moderna e la produzione Olivari". Si attivano inoltre nuovi prestigiosi contatti: inizia un duraturo rapporto di scambio progettuale e umano con Vico Magistretti, Andrea Branzi, Richard Sapper, Paolo Portoghesi, Oscar Tusquets e Massimo Iosa Ghini.

Nello stesso periodo s'introduce la tecnica della forgiatura a caldo che in pochi anni sostituisce completamente la pressofusione. Gli anni

In the 1980s, the third generation of the Olivari family progressively came to the fore. The brothers Antonio, Giovanni, Giuseppe, Carlo and Enrico were the company's new blood, and they forged ahead with design-related and technological evolution.

## 1990-2010

The 1990s were distinguished by the fruitful collaboration with Alessandro Mendini, who promoted the public appreciation of the company's historical heritage. He encouraged the brothers to tell their manufacturing story in the book "L'architettura presa per mano. La maniglia moderna e la produzione Olivari".

New prestigious contacts arrived with Vico Magistretti, Andrea Branzi, Richard Sapper, Paolo Portoghesi, Oscar Tusquets and Massimo Iosa Ghini, with whom the company established enduring bonds of friendship and design exchange.

At the same time, the technique of hot forging was introduced, and in a few years' time it substituted die-casting entirely.

The 2000s offered the opportunity for another expansion of the



Duemila sono l'occasione per un ulteriore ampliamento produttivo; oltre al pieno controllo del ciclo industriale con l'inclusione di tutte le fasi di lavorazione all'interno dell'azienda, compresa la componentistica, si provvede a investire su processi produttivi altamente automatizzati e organizzati secondo le tecnologie più avanzate. Dalla ricerca di finiture innovative e più sostenibili nascono Biocromo e SuperFinish: finiture con elevatissime prestazioni e rispettose dell'ambiente.

Olivari continua la vocazione a dialogare con il mondo del design e del progetto. Il confronto con i più noti designer della scena milanese, tra cui Enzo Mari, Rodolfo Dordoni, Piero Lissoni, James Irvine e Patricia Urquiola, si affianca alla collaborazione con i grandi protagonisti dell'architettura contemporanea: Shigeru Ban, Steven Holl, Toyo Ito, Daniel Libeskind, Peter Marino, Dominique Perrault.

Sul tema del prodotto l'Ufficio Tecnico interno studia e lancia tutta una serie di maniglie costruite sul tema geometrico del quadrato: sorprendenti per il mercato, si rivelano un grande successo.

production capabilities. In addition to the full control over the industrial cycle by encompassing all processing phases inside the company, components included, investments were made in highly automated manufacturing techniques, organised according to the most advanced technological insights.

Research on innovative, more sustainable finishes resulted in Biocromo and SuperFinish, with very elevated performance factors and respect for the environment. Olivari proceeded to follow its vocation for dialogue with the world of design and architecture.

Exchange with the most famous designers of the Milan scene – Enzo Mari, Rodolfo Dordoni, Piero Lissoni, James Irvine and Patricia Urquiola – was flanked by collaboration with the great maestri of contemporary architecture – Shigeru Ban, Steven Holl, Toyo Ito, Daniel Libeskind, Peter Marino and Dominique Perrault. Olivari's internal technical department presented the results of a study based on the geometric figure of the square. These handles were launched to great commercial success and acclaimed for their novelty.



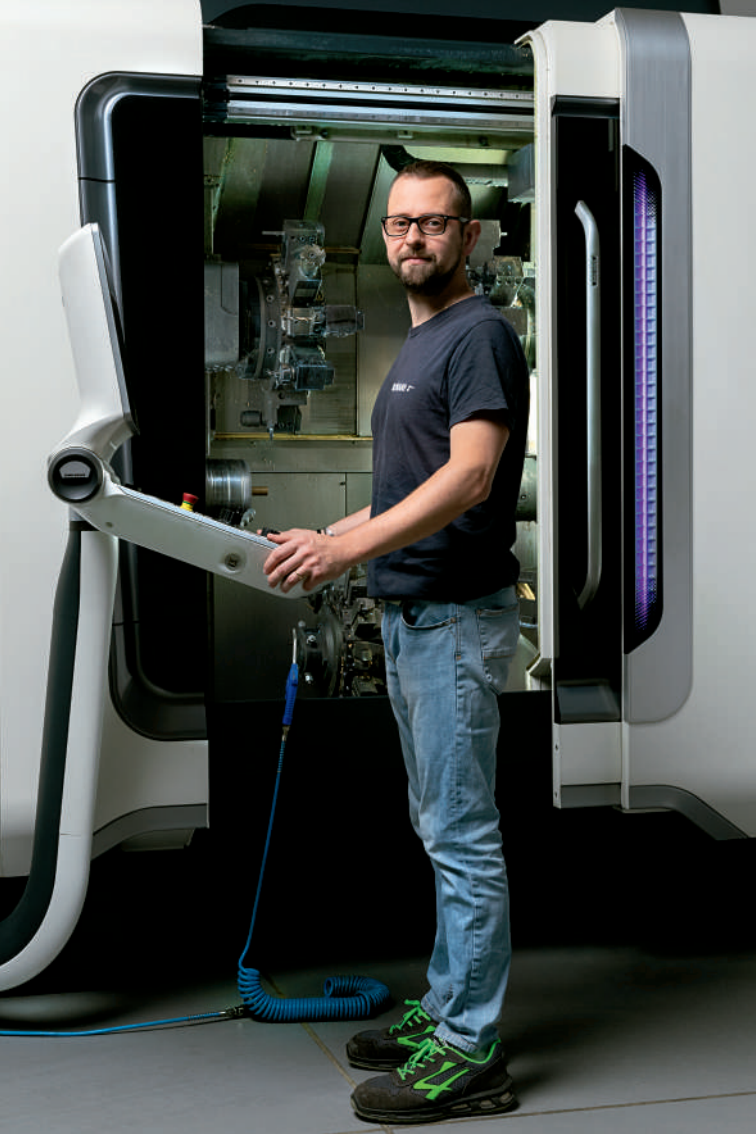

## 2010-2022

Gli anni Duemiladieci – si aprono con la celebrazione del primo centenario di vita della Olivari. Il libro “Macchina semplice. Dall’architettura al design. 100 anni di maniglie Olivari” è presentato nella simbolica sede della Biennale dell’Architettura, a Venezia, che offre anche l’occasione per presentare il primo nucleo del futuro Museo Olivari. Rinnoviamo completamente la Palazzina Uffici e si festeggia l’anniversario con grandi allestimenti al Salone del Mobile e in Triennale, a Milano. Sul fronte della comunicazione si avvia il completo rinnovamento dell’identità grafica.

Nell’ambito del progetto si introduce un nuovo tema formale, quello della “componentistica bassa” con l’obiettivo di rendere più moderne ed eleganti le nuove maniglie grazie alla miniaturizzazione dei particolari tecnici. Nel contempo si introducono nuove soluzioni espressive tramite la riscoperta dell’incisione “guilloché”. Si aprono inoltre nuove collaborazioni con architetti e designer della scena internazionale. Entrano a far parte del catalogo Olivari le maniglie di: Jean Nouvel, Ben Van Berkel/UN Studio, Marcel Wanders, Zaha Hadid, Rem Koolhaas/OMA, Ron Gilad, MAD Architects e Vincent Van Duysen. Ed oggi Carlo Colombo, Antonio Citterio, Michael Anastassiades e Barber Osgerby.

## 2010- 2022

The 2010s, and here we have arrived at present times, were opened with the celebration of Olivari’s first 100 years of business. The book “Macchina semplice” was presented in Venice at Architecture Biennale, which holds symbolic meaning for the company. There was also the occasion to introduce the first nucleus of the future Olivari Museum. Contemporaneously, construction began on the company’s new office wing, and the 100th anniversary was marked by high-impact displays at the Salone del Mobile and the Milano Triennale. As for communication, the renewal of the company’s entire visual identity was undertaken. As for production, a new category of components was introduced, its aim being to make new Olivari handles even more modern and elegant by miniaturising the internal elements and mechanisms. In the meanwhile Olivari introduced new expressive solutions as the “guilloche” incision. New collaborations were started. Handles by Jean Nouvel, Ben Van Berkel/UN Studio, Marcel Wanders, Zaha Hadid, Rem Koolhaas/OMA, Ron Gilad, MAD Architects and Vincent Van Duysen were added to the Olivari range. Today: Carlo Colombo, Antonio Citterio, Michael Anastassiades and Barber Osgerby.





# PVD Superfinish®

## Trattamento di protezione garantito

### CICLO TECNOLOGICO

PVD Superfinish® è un ciclo tecnologico di finitura che Olivari ha sviluppato, messo a punto nei propri stabilimenti. Consiste nella deposizione, su prodotti in ottone in lega titolata, di composti metallici dalle caratteristiche eccezionali.

### PRESTAZIONI RIVESTIMENTO

Il rivestimento ottenuto con PVD Superfinish® ha elevatissime prestazioni rispetto alle sollecitazioni a cui è sottoposta la superficie del prodotto:  
ambiente corrosivo: resistente alla corrosione e all'ossidazione di ambienti aggressivi, quali salsedine, piogge acide, etc.  
ambiente esterno: resistente all'umidità, alla pioggia e alle escursioni caldo/freddo.  
raggi ultravioletti: resistente all'esposizione della luce solare diretta.

Pertanto i prodotti trattati con il ciclo PVD Superfinish® mantengono inalterati nel tempo il colore e la brillantezza della superficie.

### LUOGO DI UTILIZZO

Per le suddette caratteristiche i prodotti trattati con il ciclo PVD Superfinish® sono più adatti dei prodotti cromati per aree ad alta frequentazione (es. alberghi, negozi, edifici pubblici, etc.)

### FINITURE

Attraverso PVD Superfinish®, Olivari offre diverse finiture e colorazioni:

SuperOro lucido e satinato,  
SuperNichel lucido e satinato,  
SuperInox satinato, SuperRame satinato, SuperBronzo satinato, SuperAntracite satinato.

Leggere tolleranze cromatiche sono da considerarsi normali.

### IDENTIFICAZIONE

Tutti i prodotti PVD Superfinish® sono marchiati con il logo Olivari attraverso un nuovo sistema a laser che lo renderà indelebile. Con tale sistema viene inoltre eseguita anche la marcatura del lotto e data di produzione; questa informazione permetterà di avere la tracciabilità del prodotto ovvero di codificare e certificare il processo produttivo dei prodotti.

### PULIZIA E MANUTENZIONE

I prodotti trattati con il ciclo PVD Superfinish® richiedono una pulizia, da effettuare periodicamente con un panno inumidito d'acqua. Eventuali residui di sporcizia, aloni o tracce di calcare derivanti dall'uso intenso o dall'esposizione all'esterno, devono essere rimossi attraverso la manutenzione periodica eseguita con formulati per superfici inossidabili, che consentirà al prodotto di mantenere l'originale brillantezza superficiale.

# PVD Superfinish®

## Guaranteed protection treatment

### TECHNOLOGICAL CYCLE

PVD Superfinish® is a technological finishing cycle by Olivari after having developed and perfected it in its factories. It consists of depositing metal composites, with special features, on brass in titrated alloy.

### PLATING PERFORMANCE

The plating obtained with PVD Superfinish® performs extremely well under the various stresses the product surface is subjected to: corrosive environment: resistant to the corrosion and oxidation of aggressive environments such as salinity, acid rain, etc.

outdoor environment: resistant to damp, rain and hot-cold ranges.

ultraviolet rays: resistant to exposure to direct sunlight.

Therefore the products treated with the PVD Superfinish® cycle maintain unaltered surface colour and lustre over time.

### PLACES OF USE

For the above-mentioned characteristics, products treated with the PVD Superfinish® cycle are more suitable than chrome products for highly frequented areas (for example hotels, shops, public buildings, etc.)

### FINISHES

Through PVD Superfinish®, Olivari can offer various finishes and colors:

SuperGold bright and satin,  
SuperNickel bright and satin,  
SuperStainlessSteel satin,  
SuperCopper satin, SuperBronze satin, SuperAnthracite satin.

Slight chromatic tolerances are to be considered normal.

### IDENTIFICATION

All PVD Superfinish® products are marked with the Olivari logo with the new laser system making the Olivari logo indelible.

Furthermore, the lot marking and the production date are also obtained with such system; this information guarantees the traceability of the products, i.e. the products' manufacturing process is codified and certified.

### CLEANING AND MAINTENANCE

Products treated with the PVD Superfinish® cycle require periodic cleaning with a slightly water-dampened cloth.

Any possible dirt, marks or traces of lime caused by intensive use or exposure to the elements, must be removed by periodic maintenance, using especially formulated products for stainless surfaces that make it possible to maintain the original lustre of the product surface.

# DK di sicurezza

## Sistema antintrusione

### ANTINTRUSIONE

Il DK di SICUREZZA è sistema antintrusione sempre attivo. Impedisce di azionare la leva della maniglia dall'esterno, sia facendo un foro nel serramento al disotto della maniglia nel quale poi introdurre un apposito utensile sagomato per far compiere la rotazione alla maniglia e provocare l'apertura del serramento, né facendo un foro in corrispondenza del quadro della maniglia, poiché il quadro non è più azionabile dall'esterno in quanto bloccato dal pulsante di sicurezza.

### SICUREZZA PER BAMBINI

Con questo sistema, la possibilità di aprire una finestra da parte di un bambino è resa più difficoltosa: occorre infatti un'azione combinata di pressione sul pulsante e di rotazione della maniglia.

### ADATTABILITÀ A TUTTI I MODELLI

Il sistema, che può essere applicato a tutti i modelli OLIVARI, è composto da un particolare meccanico interno che termina esternamente con un semplice pulsante posto sulla placchetta del DK. La sua presenza non è invadente, ha un ingombro limitato e può essere posizionato sia verso l'alto che verso il basso. Il DK di SICUREZZA è un brevetto Olivari.

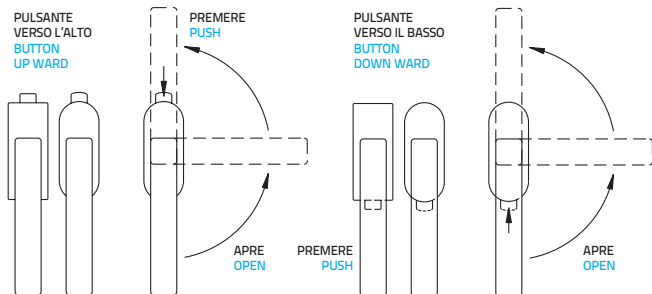

# DK by security

## Anti-intrusion system

### ANTI-INTRUSION

The DK by SECURITY is a valid anti-intrusion system and it is always activated. Any ill-intentioned person will not be able to turn the handle's bar from the outside neither by making a hole in the frame below the handle into which a special shaped tool is introduced to then let the handle rotate and the frame open, nor by making a hole at the handle's spindle as this cannot be turned from the outside since it is blocked by the security block.

### SAFE FOR CHILDREN

Thanks to this system, it is more difficult for children to open the window. It is, in fact, necessary to press the button and rotate the handle at the same time.

### SUITABLE FOR ALL MODELS

The system, which can be used with all OLIVARI models, is made of a particular internal mechanism that ends with a normal button on the DK plate. It does not interfere; it occupies a limited space and can be mounted both upwards and downwards.

The DK by SECURITY is Olivari patent.

# Componenti basse

## Low components

### DETTAGLI IMPORTANTI

L'innovativa rosetta bassa Olivari è la metà di una tradizionale – solo cinque millimetri di spessore – pur mantenendo la molla di ritorno al suo interno.

Grazie a ciò la componentistica bassa si può montare su qualunque porta.

Il miglioramento estetico è decisivo: la presenza delle parti fisse è meno invadente e la linea della maniglia resta in primo piano.

La rosetta bassa è compatibile con tutti i modelli Olivari con rosetta tonda o quadra.

Le componenti basse sono un brevetto Olivari.

### IMPORTANT DETAILS

Olivari's innovative thin escutcheon and rosette is only 1/5 inch (5 mm) thick, half the traditional thickness. The return spring is still installed inside, so this thinner device can be assembled on any door.

It definitely looks better: the immobile parts stand out less and the handle's lines stand out more. The thin escutcheon is compatible with all the Olivari models with a round or square escutcheon. The flat hardware are Olivari patent.

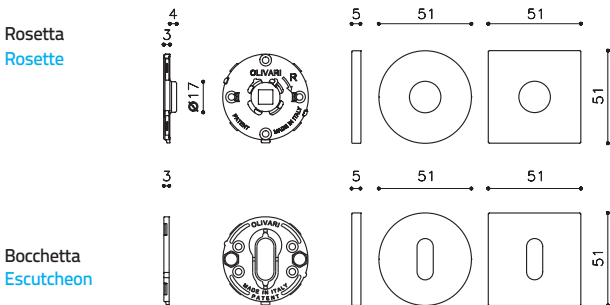

# Componenti per porte blindate

## Components for armored doors

Il nuovo programma di componenti per porte blindate, consente di realizzare un coordinamento estetico con le porte interne.

Sul lato interno della porta blindata si potrà installare lo stesso modello di maniglia e la stessa finitura delle porte interne.

Sul lato esterno si potrà scegliere di utilizzare un modello di maniglia e una finitura della porta blindata differenti, in accordo estetico con le esigenze del condominio o dell'architettura della casa, mantenendo le certificazioni di sicurezza della porta blindata.

The new program of armored door components allows you to create aesthetic coordination with internal doors.

On the inner side of the armored door you can install the same door handle model and the same finish of the internal doors.

On the external side you can choose to use different door handle model and finish for the armored door, in accordance with the aesthetic needs of the condominium or the house architecture, maintaining the safety certifications of the armored door.

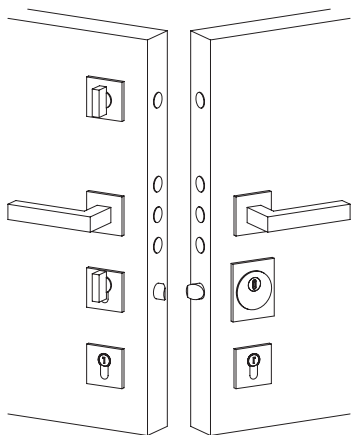



# Bibliografia/Bibliography



**L'ARCHITETTURA PRESA PER MANO**  
La maniglia moderna e la produzione Olivari.

A cura di Stefano Casciani, 1992.

**MACCHINA SEMPLICE**  
Dall'architettura al design, 100 anni di maniglie Olivari.

A cura di Stefano Casciani, 2011.

**ECCENTRIC**  
Un'antologia eccentrica, un diario di bordo di ragionamenti emersi nel corso del di un nuovo progetto Guilloché.

A cura di Francesca Picchi, 2017.

**GIO PONTI RELIGHT**  
Affinità elettive tra Ponti e Olivari.

A cura di Marco Strina, 2018.

**VIETATO L'INGRESSO**  
Un racconto, attraverso spazi, porte e maniglie, dei camerini del TAM.

A cura di Marco Strina, 2021.

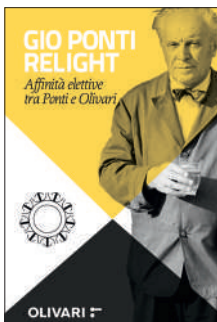
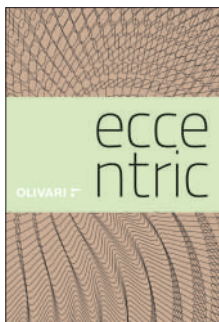
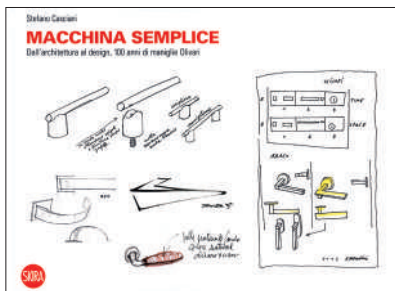



# Fiere/Exhibitions

Salone del Mobile di Milano  
Allestimenti a cura di architetti  
CalviBrambilla 2011/2022

Salone del Mobile di Milano,  
Design by architects CalviBrambilla  
2011/2022



# I nostri progettisti / Our Designers



F. Albini e F. Helg (IT)



M. Anastassiades (CY)



Sergio Asti (IT)



Shigeru Ban (JP)



Barber Osgerby (GB)



BBPR (IT)



Claudio Bellini (IT)



Ben Van Berkel (NL)



Rodolfo Bonetto (IT)



Andrea Branzi (IT)



L. Caccia Dominioni (IT)



Luca Casini (IT)



Antonio Citterio (IT)



Carlo Colombo (IT)



Joe Colombo (IT)



Rodolfo Dordoni (IT)



Ignazio Gardella (IT)



Ron Gilad (IL)



Stefano Giovannoni (IT)



Giorgetto Giugiaro (IT)



Zaha Hadid (GB)



Steven Holl (US)



Massimo Iosa Ghini (IT)



James Irvine (GB)



Toyo Ito (JP)



Rem Koolhaas (NL)



Daniel Libeskind (US)



Piero Lissoni (IT)



Javier Lopez (ES)



MAD Architects (CP)



Vico Magistretti (IT)



Angelo Mangiarotti (IT)



Enzo Mari (IT)



Peter Marino (US)



Alessandro Mendini (IT)



Monti G.P.A. (IT)



Marcello Nizzoli (IT)



Jean Nouvel (FR)



Nicola Novelletto (IT)



Max Pajetta (IT)



Dominique Perrault (FR)



Marcello Piacentini (IT)



Gio Ponti (IT)



F.A. Porsche (DE)



Paolo Portoghesi (IT)



Richard Sapper (DE)



Franco Sargiani (IT)



Patricia Urquiola (ES)



Vincent VanDuysen (NL)



Marcel Wanders (NL)

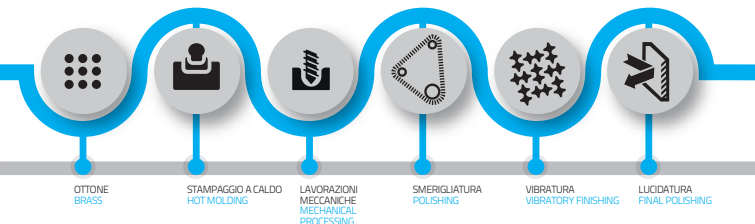

## Ciclo di produzione

L'intero ciclo produttivo si svolge esclusivamente all'interno degli stabilimenti Olivari di Borgomanero. Questa caratteristica distintiva assicura l'elevata costanza qualitativa e la durata nel tempo. I prodotti Olivari, esclusivamente realizzati in ottone, sono sottoposti a una precisa sequenza di fasi di lavoro: forgiatura a caldo e tranciatura, lavorazioni meccaniche, smerigliatura, vibratura, lucidatura, deposizione galvanica, rivestimento PVD e laseratura identificativa. Anche tutta la componentistica tecnica, sia in resina o in lamiera, è stampata e assemblata nello

stesso stabilimento. Ogni fase del ciclo produttivo prevede scrupolosi controlli, che garantiscono una qualità costante nel tempo. Olivari ha adottato i criteri dell'International Organization for Standardization per i Sistemi di gestione della qualità. Le certificazioni ISO 9001, per il Sistema di gestione delle fasi progettuali, e ISO 14000, per il Sistema di gestione della protezione dell'ambiente, confermano l'impegno che Olivari ha sempre perseguito nel garantire la qualità dei prodotti, nel pieno rispetto del personale, dell'ambiente e del territorio.

## Materiale

Per tutti i prodotti utilizziamo esclusivamente ottone. Le forme sono ottenute tramite forgiatura a caldo e lavorazione meccanica con asportazione di truciolo. Solo così possiamo ottenere prodotti e-

senti da porosità e inclusioni. Con queste premesse si ottengono le caratteristiche ottimali di preparazione alle deposizioni metalliche di cromatura e di superfinitura PVD.

## Cromatura galvanica

L'applicazione galvanica di strati metallici di nichel e di cromo rende il prodotto resistente all'abrasione e all'ossidazione. L'impianto di galvanica, automatizzato e programmabile rispetta le più recenti normative di qualità, di sicurezza e di ambiente. I prodotti cromati superano

le 1.000 ore in nebbia salina e possiedono una durezza superficiale di 800 micro Vickers. Se usata secondo le istruzioni d'uso e manutenzione, la finitura Cromo ha una garanzia di 10 anni.

## Superfinitura PVD

La metallizzazione sottovuoto (Physical Vapor Deposition) è un trattamento utilizzato nel campo degli utensili per lavorare l'acciaio ad alta velocità. Viene realizzato sul prodotto già cromato e consente di ottenere la massima resistenza all'usura: la durezza superficiale diviene pari a tre volte quella della cromatura.

Dal 2004 questa tecnologia è presente in Olivari e permette anche di ottenere colorazioni metalliche non realizzabili con la galvanica tradizionale. Se usate secondo le istruzioni d'uso e manutenzione, le Superfiniture Oro, Nichel e Inox hanno una garanzia di 30 anni; le Superfiniture Antracite, Rame e Bronzo di 10 anni.

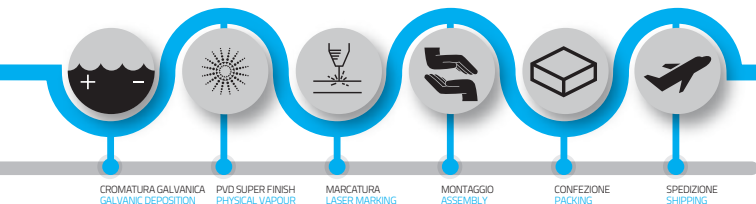

## Production cycle

A distinctive feature at Olivari is the fact that the entire manufacturing process takes place exclusively at the Olivari factory in Borgomanero. This special feature ensures constant high quality, dependability and durability. Made only in brass, Olivari products go through a precise sequence of phases: hot forging and shearing, mechanical processing, grinding, vibratory finishing, polishing, galvanic deposition, physical vapour deposition (PVD) and laser marking. In addition, all the technical components made in resin, brass sheet and steel sheet

are forged and assembled in the same factory. Every phase of the production cycle is meticulously controlled to guarantee constant quality over time.

Olivari has adopted the criteria of the International Organization for Standardization for quality management principles. Olivari has the certifications ISO 9001 for the management of the design phases, and ISO 14000 for environmental management, proving its commitment to offering quality products in full respect for employees, the environment and the local territory.

## Material

Olivari uses only titrated and certified brass. The shapes are obtained by hot forging and mechanical processing with swarf removal. These allow Olivari to obtain products devoid of porosity and

inclusions. With these measures, Olivari obtains the optimum conditions of preparation for the metal depositions of chromium plating and physical vapour deposition coatings under high vacuum.

## Galvanised chromium plating

The galvanisation process of applying metallic coats of nickel and chrome makes the product abrasion-resistant and corrosion-resistant. The automated, programmable galvanising plant respect of the most recent legal regulations concerning quality, safety and environ-

ment. Olivari's chromed products offer corrosion protection for over 1,000 hours of exposure to salt spray, and possess surface hardness equal to 800 HV. If used in accordance with the instructions and maintenance guidelines, Olivari Chrome Finishing has a 10-year guarantee.

## Superfinishing with physical vapour deposition

Vacuum metallisation (PVD) is a treatment employed for the tools used in high-velocity steel machining. It is applied to products that have already been chromed, in order to obtain maximum resistance to wear and tear. PVD increases the surface hardness to three times that of chromium plating. Since

2004 Olivari has been using PVD, which has the additional benefit of offering metallic colours that cannot be produced with galvanisation. If used in accordance with the instruction Superfinishing in Gold, Nickel and Stainless Steel have a 30-year guarantee. Anthracite, Copper and Bronze have a 10-year guarantee.

# Certificazioni / Certifications

Azienda con sistema di "QUALITÀ" certificato ISO 9001 N°0929/8

ISO 9001 certified "QUALITY" management

Olivari ha adottato un sistema di gestione della qualità che ha ottenuto il certificato UNI EN ISO 9001 con il numero 0929/8. Tutte le maniglie sono realizzate con un ciclo di produzione completamente interno all'azienda, ed ogni fase di lavorazione è controllata direttamente negli stabilimenti Olivari di Borgomanero (NO) Italia.

Olivari has implemented a quality management system that attained UNI EN ISO 9001 certification no. 0929/8. All its handles are manufactured entirely within the company. Each manufacturing phase is directly controlled in Olivari's Borgomanero (NO) Italy plant.

Azienda con sistema "AMBIENTALE" certificato ISO 14001 N°0380A/3

ISO 14001 certified "ENVIRONMENTAL" management

Olivari ha ottenuto il certificato UNI EN ISO 14001 numero 0380A/3. Questa certificazione rappresenta il riconoscimento che la gestione ambientale adottata dall'azienda non solo è conforme a tutte le prescrizioni in materia, ma che l'intero processo produttivo è continuamente monitorato al fine di prevenire ogni forma di inquinamento.

Olivari has obtained UNI EN ISO 14001 Certificate no. 0380A/3. This acknowledges that the company's environmental management not only complies with all regulations, but that the entire manufacturing process is continuously monitored to avoid any kind of pollution.

Attestato di resistenza al fuoco secondo la EN 1634-2

Certificate of fire resistance and smoke control EN 1634-2

Olivari ha ottenuto dal Laboratorio LAPI l'Attestato di resistenza al fuoco in conformità con la Normativa europea EN 1634-2, ed. 2008, con resistenza superiore ai 60 minuti. Questo significa che le maniglie Olivari in esso specificate possono sostituire quelle presenti sulle porte conformi alla Normativa europea 1634-1 e certificate REI 60, mantenendo per queste porte la validità della certificazione ottenuta.

Olivari has obtained from the L.A.P.I. laboratory the certificate of fire resistance corresponding to the European norm EN 1634-2 (2008) – resistance superior to 60 minutes. This means that the Olivari handles of this type can substitute those present on doors that meet the European norm 1634-1 and those with certified fire resistance REI 60, maintaining the validity of these doors' obtained certification.





# maniglie/door handles



## ABC

Rem Koolhaas

□ 38



## Time Q

Alessandro Mendini

□ 42



## Arc

Rodolfo Dordoni

□ 48



## Milano Q

Antonio Citterio

□ 38



## Minerva

Franco Sargiani

□ 43



## Living

Dominique Perrault

□ 39



## Bios

Franco Sargiani

□ 43



NEW

## Paddle

E. Barber, J. Osgerby

○ 50



## Total

Rodolfo Dordoni

□ 39



## Planet Q

Luca Casini

□ 44



NEW

## Okay

Michael Anastassiades

○ 50



## Lotus Q

Javier Lopez

□ 40



## Diana

Studio Olivari

□ 46



NEW

## Dynamic

Studio Olivari

○ 51



## Trend

Studio Olivari

□ 40



## Blade

Peter Marino

□ 46



## Open

OMA/Rem Koolhaas

○ 52



## Sky

Claudio Bellini

□ 41



## Adamant

Patricia Urquiola

□ 47



## Lotus

Javier Lopez

○ 52



## Denver

Daniel Libeskind

□ 41



## Chevron

Zaha Hadid

□ 47



## Plume

Piero Lissoni

○ 53



## Space Q

Alessandro Mendini

□ 42



## Euclide Q

Nicola Novelletto

□ 48



## Twist

Ben Van Berkel

○ 53



**Square** rosetta quadrata/**square rosette**  
**Round** rosetta tonda/**round rosette**  
**Special** con materiali o lavorazioni particolari/**with particular materials or processes**



**Marbella**  
Studio Olivari ○ 54



**Time**  
Alessandro Mendini ○ 58



**Milano**  
Antonio Citterio ○ 64



**Tecno**  
Giorgetto Giugiaro ○ 54



**Lucy**  
Patricia Urquiola ○ 59



**Icona**  
Vincent Van Duysen ○ 65



**Nina**  
Daniel Libeskind ○ 55



**Virgola**  
Ron Gilad ○ 59



**Link**  
Piero Lissoni ○ 65



**Alexandra**  
F.A. Porsche ○ 55



**Dolce Vita**  
Marcel Wanders ○ 60



**Logo**  
James Irvine ○ 66



**Lama**  
Gio Ponti ○ 56



**Beijing**  
Steven Holl ○ 60



**Radial**  
Rodolfo Dordoni ○ 66



**Lama L**  
Gio Ponti ○ 56



**Stilo**  
Enzo Mari ○ 61



**Laser**  
Richard Sapper ○ 67



**Ala**  
Massimo Iosa Ghini ○ 57



**Euclide**  
Nicola Novelletto ○ 61



**Lugano**  
Carlo Colombo ○ 67



**Fin**  
Toyo Ito ○ 57



**Planet**  
Luca Casini ○ 62



**Raffaella**  
Studio Olivari ○ 68



**Space**  
Alessandro Mendini ○ 58



**Beta**  
Joe Colombo ○ 64



**Chiara**  
Studio Olivari ○ 68

**Tizianella F**

Sergio Asti ○ 69

**Orvieto**

Novelletto, Volonterio ○ 73

**Futura**

Studio Olivari ○ 78

**Serenella**

Studio Olivari ○ 69

**Bond**

Andrea Branzi ○ 74

**Aster**

Studio Olivari ○ 78

**Selene**

Massimo Iosa Ghini ○ 70

**Golia**

Studio Olivari ○ 74

**Sibilla**

Vico Magistretti ○ 79

**Wind**

Studio Olivari ○ 70

**Emilia**

Studio Olivari ○ 75

**Marilyn**

MAD Architects ○ 79

**Onda**

Nicola Novelletto ○ 71

**Diva**

Luca Casini ○ 75

**Polo**

Rodolfo Bonetto ○ 80

**Novella**

Novelletto, Volonterio ○ 71

**Flaminia**

Studio Olivari ○ 76

**Garda**

Ignazio Gardella ○ 80

**Vola**

Max Pajetta ○ 72

**Comet**

Nicola Novelletto ○ 76

**Blindo**

Studio Olivari ○ 81

**Agata**

F. Albini, F. Helg ○ 72

**Aurelia**

Studio Olivari ○ 77

**Uovo**

Studio Olivari ○ 81

**Siena**

Novelletto, Volonterio ○ 73

**Sector**

Studio Olivari ○ 77

**Conca**

Patricia Urquiola ○ 82



**Ice Cube**  
Dominique Perrault □ 84



**Edge**  
Peter Marino □ 87



**Atena Panier**  
Studio Olivari ○ 89



**Aurora**  
Alessandro Mendini ○ 84



**Diana Barley**  
Studio Olivari □ 88



**Crystal Diamond**  
Marcel Wanders ○ 85



**Diana Damier**  
Studio Olivari □ 88



**Crystal Royal**  
Marcel Wanders ○ 85



**Diana Chevron**  
Studio Olivari □ 88



**Boma**  
Monti G.P.A. ○ 188



**Chelsea**  
Jean Nouvel ○ 86



**Atena Ligne**  
Studio Olivari ○ 89



**Iseo**  
Sergio Asti ○ 188



**Club**  
Vico Magistretti ○ 86



**Atena Rank**  
Studio Olivari ○ 89



**Chiara**  
Studio Olivari ○ 189

## complementi/complements

**Maniglie da finestra**  
Window handles 92

**Maniglie placca orizzontale**  
Door handles horizontal plate 120

**Pomoli**  
Door knobs 122

**Pomoli a T**  
T door knobs 130

**Chiavistelli porte interne**  
Latches internal doors 134

**Mezzi chiavistelli hotel**  
Half latches hotel 144

**Maniglie incasso**  
Flush handles 150

**Maniglioni**  
Pull handles 158

**Maniglioni alzanti**  
Pull-up handles 166

**Fermaporte**  
Door stoppers 174

**Componenti porte blindate**  
Components armored doors 176

**Nylon**  
Nylon 188

## Finiture galvaniche

La maniglia in ottone, nell'impianto galvanico, viene rivestita da uno strato metallico di nichel-cromo con la funzione di proteggerla dall'usura e dalla corrosione.

Galvanisation of the brass handle gives it a protective metal coat of nickel-chromium to guard against wear and corrosion.



CR  
Cromo lucido  
Bright chrome



CO  
Cromo satinato  
Satin chrome

## Finiture verniciate

La verniciatura, effettuata con polvere epossidica, ha uno spessore di circa 80 micron e conferisce al prodotto una finitura molto accattivante. Se usata secondo le istruzioni d'uso e manutenzione, la finitura verniciata ha una vita lunga. L'elevata frequenza di utilizzo e l'eventuale esposizione agli agenti atmosferici possono ridurre la vita utile del prodotto.

Epoxy-based powder coating, about 80 microns thick, offers a very attractive finish with great longevity, provided the product is used in accordance with the instructions and maintenance guidelines. High-intensity use and exposure to the elements can limit the product's lifespan.



NP  
Nero opaco  
Matt black



BP  
Bianco opaco  
Matt white

# Finiture PVD Superfinish®

La maniglia, cromata lucida o satinata, nell'impianto di metallizzazione sottovuoto viene rivestita da uno strato ulteriore, costituito da composti nano-metallici di straordinaria durezza, che determinano la specifica colorazione e preservano la superficie dall'usura, dall'incisione e dagli agenti più aggressivi: umidità, sudore, salsedine, sbalzi termici e raggi ultravioletti.

With physical vapour deposition, a polished or satin-finish chrome handle is coated with an ulterior layer of metal (superfinishing) under high vacuum. Vacuum metallisation is extremely hard and durable. Nanocomposites of metal determine the specific colour of the surface and protect it from wear, scratches and aggressive substances such as humidity, sweat, salt spray, temperature swings and ultraviolet rays.



**NL**  
SuperNickel lucido  
SuperNickel bright



**NS**  
SuperNickel satinato  
SuperNickel satin



**IS**  
SuperInox satinato  
SuperStainlessSteel satin



**ZL**  
SuperOro lucido  
SuperGold bright



**TS**  
SuperOro satinato  
SuperGold satin



**US**  
SuperAntracite satinato  
SuperAnthracite satin



**RS**  
SuperRame satinato  
SuperCopper satin



**DS**  
SuperBronzo satinato  
SuperBronze satin

## finiture/finishes

- CR** Cromo lucido/Bright chrome
- CA** Cromo lucido-satinato/Chrome bright-satin
- CO** Cromo satinato/Satin chrome
- NP** Nero opaco/Matt black
- BP** Bianco opaco/Matt white
- ZL** SuperOro lucido/SuperGold bright
- ZT** SuperOro lucido-satinato/SuperGold bright-satin
- TS** SuperOro satinato/SuperGold satin
- NL** SuperNichel lucido/SuperNickel bright
- NS** SuperNichel satinato/SuperNickel satin
- IS** SuperInox satinato/SuperStainlessSteel satin
- RS** SuperRame satinato/SuperCopper satin
- DS** SuperBronzo satinato/SuperBronze satin
- US** SuperAntracite satinato/SuperAnthracite satin

# Square

Maniglie da porta  
su rosetta quadra

Door handles  
on square rosette

Square

# ABC

Rem Koolhaas

M255B



■ CR ■ CO ■ IS ■ RS ■ DS ■ US

---

# Milano Q

Antonio Citterio

M260B



■ CR ■ CO ■ IS ■ DS ■ US



# Living

Dominique Perrault

M222B



■ CR ■ CO ■ IS ■ US

---

# Total

Rodolfo Dordoni

M207



■ CR ■ CO ■ NP ■ IS ■ RS ■ DS ■ US

Square

# Lotus Q

Javier Lopez

M241B

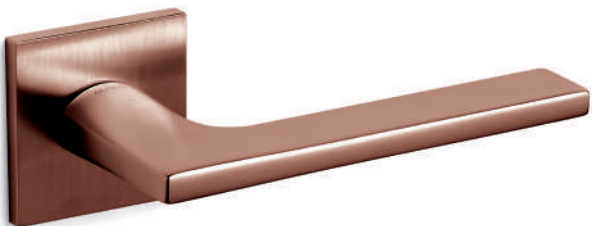

■ CR ■ CO ■ NP ■ BP ■ TS ■ NL ■ NS ■ IS ■ RS ■ DS ■ US

---

# Trend

Studio Olivari

M228B



■ CR ■ CO ■ IS ■ RS ■ US

# Sky

Claudio Bellini

M214



■ CR ■ CO ■ DS

---

# Denver

Daniel Libeskind

M218



■ CR ■ CO ■ IS

Square

# Space Q

Alessandro Mendini

M202



■ CA ■ CO ■ IS

---

# Time Q

Alessandro Mendini

M201



■ CA ■ CO ■ MW ■ IS

# Minerva

Franco Sargiani

M205



■ CR ■ CO ■ IS ■ US

---

# Bios

Franco Sargiani

M204



■ CR ■ CO ■ IS ■ DS ■ US

Square

# Planet Q

Luca Casini

M203



CR CO ZL NL NS IS RS DS US

---

# Planet Q bassa

Luca Casini

M203B



CR CO NP BP ZL TS NL NS IS RS DS US

# Planet Q bicolor

Luca Casini

M203



■ CA ■ ZT

---

# Planet Q bicolor bassa

Luca Casini

M203B



■ CA ■ ZT

Square

# Diana

Studio Olivari

M206



CR CO NL IS RS DS US

---

# Blade

Peter Marino

M213



CR CO



# Adamant

Patricia Urquiola

M216



■ CR ■ CO



# Chevron

Zaha Hadid

M248B



■ CR ■ CO ■ DS ■ US

Square

# Euclide Q

Nicola Novelletto

M230B

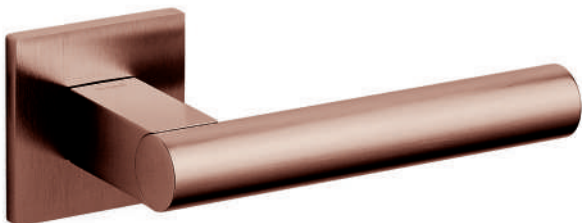

■ CR ■ CO ■ NL ■ RS ■ DS ■ US

---

# Arc

Rodolfo Dordoni

M225B



■ CR ■ CO

# Round

Maniglie da porta  
su rosetta tonda

Door handles  
on round rosette

Round

# Paddle

Edward Barber, Jay Osgerby

M264B

NEW



CR CO NP BP TS NS RS DS US

---

# Okay

Michael Anastassiades

M262B

NEW



CR CO NP NS IS DS US

Dynamic  
Studio Olivari  
M261B

NEW



■ CR ■ CO ■ NP ■ NS ■ IS ■ DS ■ US



Round

# Open

OMA/Rem Koolhaas

M249B



■ CR ■ CA ■ CO ■ IS ■ RS ■ DS ■ US

# Lotus

Javier Lopez

M238B



■ CR ■ CO ■ NP ■ BP ■ TS ■ NL ■ NS ■ IS ■ RS ■ DS ■ US

# Plume

Piero Lissoni

M253B



CR CO ZL RS DS US

---

# Twist

Ben Van Berkel

M242B



CR CO NL IS RS US

Round

# Marbella

Studio Olivari

M237B



■ CR ■ CO ■ IS ■ DS

---

# Tecno

Giorgetto Giugiaro

M182



■ CR ■ CO ■ ZL ■ TS ■ NS ■ IS ■ DS



# Nina

Daniel Libeskind

M234



■ CR ■ CO ■ IS ■ US

---

# Alexandra

F.A. Porsche

M150



■ CR ■ CO ■ IS

Round

# Lama

Gio Ponti  
M107



CR CO ZL TS IS US

---

# Lama L

Gio Ponti  
M106B



CR CO NP BP ZL TS NL NS IS RS DS US

# Ala

Massimo Iosa Ghini

M215



■ CR ■ CO



# Fin

Toyo Ito

M217



■ CR ■ CO ■ NL ■ NS

Round

# Space

Alessandro Mendini

M193



■ CA ■ CO ■ IS

---

# Time

Alessandro Mendini

M192



■ CA ■ CO ■ MW ■ IS

# Lucy

Patricia Urquiola

M231B



■ CR ■ CO ■ NL ■ RS ■ US

---

# Virgola

Ron Gilad

M251B



■ CR ■ CO ■ IS ■ US

Round

# Dolce Vita

Marcel Wanders

M243B



CR CO ZL NL DS US

---

# Beijing

Steven Holl

M208



CR CO IS US

# Stilo

Enzo Mari

M190



■ CR ■ CO ■ ZL ■ IS

---

# Euclide

Nicola Novelletto

M229B



■ CR ■ CO ■ NL ■ RS ■ DS ■ US

Round

# Planet

Luca Casini

M195



CR CO NP ZL TS NL NS IS RS DS US

# Planet bassa

Luca Casini

M195B



CR CO NP BP ZL TS NL NS IS RS DS US



# Planet bicolor

Luca Casini

M195



■ CA ■ ZT

---

# Planet bicolor bassa

Luca Casini

M195B



■ CA ■ ZT

Round

# Beta

Joe Colombo

M221B



■ CR ■ CO ■ IS ■ US

---

# Milano

Antonio Citterio

M259B



■ CR ■ CO ■ IS ■ DS ■ US

# Icona

Vincent Van Duysen

M254B



CR CO NP BP NL NS IS RS DS US

---

# Link

Piero Lissoni

M200



CR CO TS NL NS IS RS DS US

## Round

# Logo

James Irvine

M197



■ CR ■ CO ■ IS

---

# Radial

Rodolfo Dordoni

M235



■ CR ■ CO ■ NP ■ IS ■ RS ■ DS ■ US

# Laser

Richard Sapper

M176



■ CR ■ CO ■ IS ■ US

---

# Lugano

Carlo Colombo

M258B



■ CR ■ CO ■ TS ■ NS ■ IS ■ RS ■ DS ■ US

Round

# Raffaella

Studio Olivari

M128



■ CR ■ CO ■ ZL ■ TS ■ IS ■ RS ■ DS ■ US

---

# Chiara

Studio Olivari

M125



■ CR ■ CO

# Tizianella F

Sergio Asti  
M112



■ CR ■ CO ■ NP ■ ZL ■ TS ■ IS

---

# Serenella

Studio Olivari  
M130



■ CR ■ CO ■ IS ■ US

Round

# Selene

Massimo Iosa Ghini

M194



■ CA ■ ZT

---

# Wind

Studio Olivari

M187



■ CR ■ CO ■ ZL ■ TS



# Onda

Nicola Novelletto

M175



■ CR ■ CO ■ ZL ■ TS ■ NL ■ IS ■ RS ■ DS

---

# Novella

Nicola Novelletto, Roberto Volonterio

M165



■ CR ■ CO ■ ZL ■ TS ■ IS ■ DS

Round

# Vola

Max Pajetta

M257B



CR CO ZL TS NS DS US

---

# Agata

Franco Albini, Franca Helg

M116



CR CO ZL

# Siena

Nicola Novelletto, Roberto Volonterio

M169



■ CR ■ CO ■ ZL ■ TS ■ DS

---

# Orvieto

Nicola Novelletto, Roberto Volonterio

M170



■ CR ■ CO ■ ZL ■ TS ■ DS

Round

# Bond

Andrea Branzi

M163



■ CO ■ ZL



# Golia

Studio Olivari

M160



■ CR ■ CO ■ ZL ■ DS

# Emilia

Studio Olivari

M167



■ CR ■ CO ■ ZL ■ TS ■ DS

---

# Diva

Luca Casini

M256B



■ CR ■ CO ■ TS ■ DS ■ US

Round

# Flaminia

Studio Olivari

M159



■ CR ■ CO ■ ZL ■ TS ■ DS

---

# Comet

Nicola Novelletto

M183



■ CA ■ CN ■ ZT

# Aurelia

Studio Olivari

M185



■ CR ■ CO ■ ZL ■ TS ■ NL ■ NS ■ IS ■ RS ■ DS ■ US

---

# Sector

Studio Olivari

M186



■ CA ■ ZT

Round

# Futura

Studio Olivari

M172



■ CR ■ CO ■ ZL ■ NS ■ IS

---

# Aster

Studio Olivari

M174



■ CA ■ ZT



# Sibilla

Vico Magistretti

M154



■ CR ■ CO



# Marilyn

MAD Architects

M252B



■ CR ■ CO ■ IS ■ DS ■ US

Round

# Polo

Rodolfo Bonetto

M152



■ CR ■ CO



# Garda

Ignazio Gardella

M105



■ CR ■ CO ■ ZL ■ DS

# Blindo

Studio Olivari

M178



■ CR ■ CO ■ ZL ■ TS ■ NL ■ NS ■ IS ■ RS ■ DS ■ US

---

# Uovo

Studio Olivari

M108



■ CR ■ CO ■ NP ■ BP ■ ZL ■ TS ■ DS

Round

# Conca

Patricia Urquiola

M236B



■ CR ■ CO ■ IS ■ RS ■ DS ■ US



# Special

Maniglie da porta  
con materiali o  
lavorazioni particolari

Door handles  
with particular  
materials  
or processes

Special

# Ice Cube

Dominique Perrault

M223B



■ C6 ■ M6

---

# Aurora

Alessandro Mendini

M164



■ C1 ■ C5 ■ C6 ■ 6M ■ Z1 ■ Z5 ■ Z6

# Crystal Diamond

Marcel Wanders

M246B



■ C6 ■ M6 ■ Z6 ■ U6

---

# Crystal Royal

Marcel Wanders

M245B



■ C6 ■ M6 ■ Z6 ■ U6

Special

# Chelsea

Jean Nouvel

M232B



■ CB ■ MB ■ CE ■ ME

---

# Club

Vico Magistretti

M181



■ XB ■ XE ■ XF ■ XL ■ XM ■ XN  
■ OB ■ OE ■ OF ■ OL ■ OM ■ ON



# Edge

Peter Marino  
M212



■ EB ■ EW ■ EA ■ MW ■ MA



Special

# Diana Barley

Studio Olivari

M1DBB

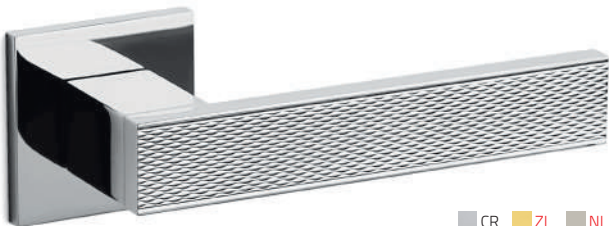

CR ZL NL

---

# Diana Damier

Studio Olivari

M1DDB



CR ZL NL

---

# Diana Chevron

Studio Olivari

M1DCB



CR ZL NL

# Atena Ligne Studio Olivari

M1ALB



CR ZL NL

---

# Atena Rank Studio Olivari

M1ARB



CR ZL NL

---

# Atena Panier Studio Olivari

M1APB



CR ZL NL



Maniglie  
da finestra

Window  
handles

## Maniglie da finestra - Window handles

### ABC

Rem Koolhaas

C255 K255B

CR/CO/IS/RS/DS/US



### Milano Q

Antonio Citterio

C260 K260B

CR/CO/IS/DS/US



---

### Living

Dominique Perrault

C222 K222B

CR/CO/IS/US



### Total

Rodolfo Dordoni

C206 K206

CR/CO/NP/IS/RS/DS/US



## Lotus Q

Javier Lopez

C241 K241B

CR/CO/NP/BP/TS/NL/NS/IS/RS/DS/US



## Trend

Studio Olivari

C228 K228B

CR/CO/IS/RS/US



---

## Sky

Claudio Bellini

C214 K214

CR/CO/ZL/NL/NS/IS/RS/DS/US



## Denver

Daniel Libeskind

C218 K218

CR/CO/DS



## Maniglie da finestra - Window handles

### Space Q

Alessandro Mendini

C201 K201

CA/CO/IS



### Time Q

Alessandro Mendini

C201 K201

CR/CO/MW/IS



---

### Minerva

Franco Sargiani

C205 K205

CR/CO/IS/US



### Bios

Franco Sargiani

C204 K204

CR/CO/IS/DS/US





## Planet Q

Luca Casini

C203 K203

CR/CO/ZL/NL/NS/IS/RS/DS/US



## Planet Q bassa

Luca Casini

C203 K203B

CR/CO/NP/BP/ZL/TS/NL/NS/IS/RS/DS/US



---

## Planet Q bicolor

Luca Casini

C203 K203

CA/ZT



## Planet Q bicolor bassa

Luca Casini

C203 K203B

CA/ZT



## Maniglie da finestra - Window handles

### Diana

Studio Olivari

C206 K206

CR/CO/NL/IS/RS/DS/US



### Blade

Peter Marino

C213 K213

CR/CO



---

### Adamant

Patricia Urquiola

C216 K216

CR/CO



### Chevron

Zaha Hadid

C248 K248B

CR/CO/DS/US



## Euclide Q

Nicola Novelletto

C230 K230B

CR/CO/NL/RS/DS/US



## Arc

Rodolfo Dordoni

C225 K225B

CR/CO



## Maniglie da finestra - Window handles

### Paddle **NEW**

Edward Barber, Jay Osgerby

C264 K264B

CR/CO/NP/BP/TS/NS/RS/DS/US



### Okay **NEW**

Michael Anastassiades

C262 K262B

CR/CO/NP/ZL/NS/IS/DS/US



---

### Dynamic **NEW**

Studio Olivari

C261 K261B

CR/CO/NP/ZL/NS/IS/DS/US



## Open

OMA/Rem Koolhaas

C249 K249B

CR/CA/CO/IS/RS/DS/US



## Lotus

Javier Lopez

C238 K238B

CR/CO/NP/BP/TS/NL/NS/IS/RS/DS/US



---

## Plume

Piero Lissoni

C253 K253B

CR/CO/ZL/RS/DS/US



## Twist

Ben Van Berkel

C242 K242B

CR/CO/NL/IS/RS/US



## Maniglie da finestra - Window handles

### Marbella

Studio Olivari

C237 K237B

CR/CO/IS/DS



### Tecno

Giorgetto Giugiaro

C182 K182

CR/CO/ZL/TS/NS/IS/DS



---

### Nina

Daniel Libeskind

C234 K234

CR/CO/IS/US



### Alexandra

F.A. Porsche

C150 K150

CR/CO/IS



## Lama

Gio Ponti

C107 K107

CR/CO/ZL/TS/IS/US



## Lama L

Gio Ponti

C107 K106B

CR/CO/NP/BP/ZL/TS/NL/NS/IS/RS/DS/US



---

## Ala

Massimo Iosa Ghini

C215 K215

CR/CO



## Fin

Toyo Ito

C217 K217

CR/CO/NL/NS



## Maniglie da finestra - Window handles

### Space

Alessandro Mendini

C192 K192

CA/CO/IS



### Time

Alessandro Mendini

C192 K192

CA/CO/MW/IS



---

### Lucy

Patricia Urquiola

C231 K231B

CR/CO/NL/RS/US



### Virgola

Ron Gilad

C251 K251B

CR/CO/IS/US





## Dolce Vita

Marcel Wanders

C243 K243B

CR/CO/ZL/NL/DS/US



## Beijing

Steven Holl

C208 K208

CR/CO/IS/US



---

## Stilo

Enzo Mari

C190 K190

CR/CO/ZL/IS



## Euclide

Nicola Novelletto

C229 K229B

CR/CO/NL/RS/DS/US



## Maniglie da finestra - Window handles

### Planet

Luca Casini

C195 K195

CR/CO/NP/ZL/TS/NL/NS/IS/RS/DS/US



### Planet bassa

Luca Casini

C195 K195B

CR/CO/NP/BP/ZL/TS/NL/NS/IS/RS/DS/US



---

### Planet bicolor

Luca Casini

C195 K195

CA/ZT



### Planet bicolor bassa

Luca Casini

C195 K195B

CA/ZT



## Beta

Joe Colombo

C221 K221B

CR/CO/IS/US



## Milano

Antonio Citterio

C259 K259B

CR/CO/IS/DS/US



---

## Icona

Vincent Van Duysen

C254 K254B

CR/CO/NP/BP/NL/NS/IS/RS/DS/US



## Link

Piero Lissoni

C200 K200

CR/CO/TS/NL/NS/IS/RS/DS/US



## Maniglie da finestra - Window handles

### Logo

James Irvine

C197 K197

CR/CO/IS



### Radial

Rodolfo Dordoni

C235 K235

CR/CO/NP/IS/RS/DS/US



---

### Laser

Richard Sapper

C176 K176

CR/CO/IS/US



### Lugano

Carlo Colombo

C258 K258B

CR/CO/TS/NS/IS/RS/DS/US



## Raffaella

Studio Olivari

C128 K128

CR/CO/ZL/TS/IS/RS/DS/US



## Chiara

Studio Olivari

C125 K125

CR/CO



---

## Tizianella F

Sergio Asti

C112 K112

CR/CO/NP/ZL/TS/IS



## Serenella

Studio Olivari

C128 K130

CR/CO/IS/US



## Maniglie da finestra - Window handles

### Selene

Massimo Iosa Ghini

C194 K194

CA/ZT



### Wind

Studio Olivari

C187 K187

CR/CO/ZL/TS



---

### Onda

Nicola Novelletto

C175 K175

CR/CO/ZL/TS/NL/IS/RS/DS



### Novella

Novelletto, Volonterio

C165 K165

CR/CO/ZL/TS/IS/DS



## Vola

Max Pajetta

C257 K257B

CR/CO/ZL/TS/NS/DS/US



## Agata

Franco Albini, Franca Helg

C116 K116

CR/CO/ZL



---

## Siena

Novelletto, Volonterio

C169 K169

CR/CO/ZL/TS/DS



## Orvieto

Novelletto, Volonterio

C170 K170

CR/CO/ZL/TS/DS



## Maniglie da finestra - Window handles

### Bond

Andrea Branzi

C163 K163

CO/ZL



### Golia

Studio Olivari

C160 K160

CR/CO/ZL/DS



---

### Emilia

Studio Olivari

C167 K167

CR/CO/ZL/TS/DS



### Diva

Luca Casini

C256 K256B

CR/CO/TS/DS/US





## Flaminia

Studio Olivari

C159 K159

CR/CO/ZL/TS/DS



## Comet

Nicola Novelletto

C183 K183

CA/CN/ZT



---

## Aurelia

Studio Olivari

C185 K185

CR/CO/ZL/TS/NL/NS/IS/RS/DS/US



## Sector

Studio Olivari

C186 K186

CA/ZT



## Maniglie da finestra - Window handles

### Futura

Studio Olivari

C172 K172

CR/CO/ZL/NS/IS



### Aster

Studio Olivari

C174 K174

CA/ZT



---

### Sibilla

Vico Magistretti

C154 K154

CR/CO



### Marilyn

MAD Architects

C252 K252B

CR/CO/IS/DS/US



## Polo

Rodolfo Bonetto

C152 K152

CR/CO



## Garda

Ignazio Gardella

C105 K105

CR/CO/ZL/DS



---

## Blindo

Studio Olivari

C178 K178

CR/CO/ZL/TS/NL/NS/IS/RS/DS/US



## Uovo

Studio Olivari

C108 K108

CR/CO/NP/BP/ZL/TS/DS



## Maniglie da finestra - Window handles

# Conca

Patricia Urquiola

C236 K236B

CR/CO/IS/RS/DS/US



## Ice Cube

Dominique Perrault

C223 K223B

C6/M6



## Aurora

Alessandro Mendini

C164 K164

C1/C5/C6/6M/Z1/Z5/Z6



---

## Crystal Diamond

Marcel Wanders

C246 K246B

C6/M6/Z6/U6



## Crystal Royal

Marcel Wanders

C245 K245B

C6/M6/Z6/U6



## Maniglie da finestra - Window handles

### Chelsea

Jean Nouvel

C232 K232B

CB/CE/MB/ME



### Club

Vico Magistretti

C181 K181

XB/XE/XF/XL/XM/XN/OB/OE/OF/OL/OM/ON



---

### Edge

Peter Marino

C212 K212

EB/EW/EA/MW/MA



## Diana Barley

Studio Olivari

C1DB K1DBB

CR/ZL/NL



## Diana Damier

Studio Olivari

C1DD K1DDB

CR/ZL/NL



---

## Diana Chevron

Studio Olivari

C1DC K1DCB

CR/ZL/NL



## Maniglie da finestra - Window handles

### Atena Ligne

Studio Olivari

C1AL K1ALB

CR/ZL/NL



### Atena Rank

Studio Olivari

C1AR K1ARB

CR/ZL/NL



---

### Atena Panier

Studio Olivari

C1AP K1APB

CR/ZL/NL





Maniglie  
su placca  
orizzontale

Door handles  
on horizontal  
plate

## Placche orizzontali - Horizontal plates

# Placca orizzontale rettangolare

Studio Olivari



CR/CO/NP/BP/ZL/TS/NL/NS/IS/RS/DS/US

Tutte le maniglie sono disponibili con placche orizzontali rettangolari  
All door handles are available with rectangular horizontal plates

# Placca orizzontale ovale

Studio Olivari

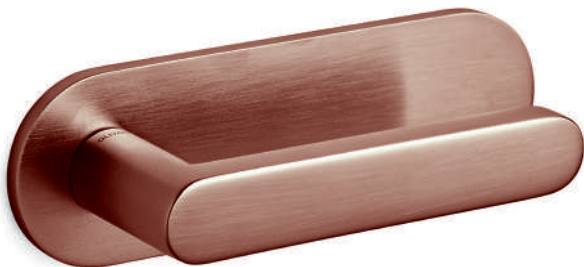

CR/CO/NP/BP/ZL/TS/NL/NS/IS/RS/DS/US

Tutte le maniglie sono disponibili con placche orizzontali ovali  
All door handles are available with oval horizontal plates

# Pomoli

## Door knobs

# Planet Q

Studio Olivari

P203



CR/CO/NS/IS

---

# Planet Q bassa

Studio Olivari

P203B



CR/CO/NS/IS

# Planet

Studio Olivari

P195



CR/CO/NS/IS

---

# Planet bassa

Studio Olivari

P195B



CR/CO/NS/IS

## Pomoli centrali - Central door knobs

# Diana

Studio Olivari

P206



CR/CO/ZL/NL/NS/IS/RS/DS/US

---

# Diana bassa

Studio Olivari

P206B



CR/CO/NP/BP/ZL/TS/NL/NS/IS/RS/DS/US

# Link

Piero Lissoni

P200



CR/CO/ZL/TS/NL/NS/IS/RS/DS/US

---

# Link bassa

Piero Lissoni

P200B



CR/CO/NP/BP/ZL/TS/NL/NS/IS/RS/DS/US

## Pomoli centrali - Central door knobs

### Oscar

Studio Olivari

P123



CR/CO/NL/RS/DS

---

### Roger

Studio Olivari

P120



CR/CO/TS/NL/RS/DS



## Edison $\varnothing$ 60

Sergio Mazza, Giuliana Gramigna  
P146



CR/CO/ZL/TS/NL/IS/RS/DS/US

---

## Edison $\varnothing$ 70

Sergio Mazza, Giuliana Gramigna  
P147



CR/CO/ZL/TS/NL/IS/RS/DS/US

## Pomoli centrali - Central door knobs

# Edison $\varnothing 80$

Sergio Mazza, Giuliana Gramigna

P148



CR/CO



Pomoli a T  
T door knobs

Pomoli a T - T door knobs

# Raffaella T

Studio Olivari

P128R

P128V

NEW



CR/CO/ZL/TS/IS/RS/DS/US

CR/CO/ZL/TS/IS/RS/DS/US

# Tizianella T

Sergio Asti

P112R

P112V

NEW



CR/CO/NP/ZL/TS/IS

CR/CO/NP/ZL/TS/IS

Pomoli a T - T door knobs

# Lama T

Gio Ponti

P107R

P107V

NEW



CR/CO/NP/BP/ZL/TS/NL/NS/IS/RS/DS/US

CR/CO/NP/BP/ZL/TS/NL/NS/IS/RS/DS/US

Chiavistelli per  
porte interne

Latches for  
internal doors

## Cubo

Studio Olivari

H136V6  
H136VF6



CR/CO/ZL/NL/NS/IS/RS/DS/US

---

## Link Q

Piero Lissoni

H209V6  
H209VF6



CR/CO/ZL/NL/NS/IS/RS/DS/US

---

## Link Q ADA

Piero Lissoni

H208V6  
H208VF6

NEW



CR/CO/ZL/NL/NS/IS/RS/DS/US



## Space Q

Studio Olivari

H202V6  
H202VF6



CR/CO/ZL/NL/NS/IS/RS/DS/US

---

## Space Q ADA

Studio Olivari

H201V6  
H201VF6

NEW



CR/CO/ZL/NL/NS/IS/RS/DS/US

---

## Verona Q

Studio Olivari

H117V6  
H118V6



CR/CO/ZL/NL/NS/IS/RS/DS/US

## Chiavistelli per porte interne - Latches for internal doors

### Link

Piero Lissoni

H200V6  
H200VF6



CR/CO/ZL/TS/NL/NS/IS/RS/DS/US

---

### Link ADA

Piero Lissoni

H197V6  
H197VF6

NEW



CR/CO/ZL/TS/NL/NS/IS/RS/DS/US

---

### Space

Studio Olivari

H193V6  
H193VF6



CR/CO/ZL/TS/NL/NS/IS/RS/DS/US

## Space ADA

Studio Olivari

H191V6

H191VF6

NEW



CR/CO/ZL/TS/NL/NS/IS/RS/DS/US

---

## Verona V

Studio Olivari

H106V6

H109V6



CR/CO/NP/ZL/TS/NL/NS/IS/RS/DS/US

---

## Verona R

Studio Olivari

H107R6

H108R6



CR/CO/ZL/TS/NL/NS/IS/RS/DS/US

## Chiavistelli per porte interne - Latches for internal doors

### Cubo bassa

Studio Olivari

H136V6B

H136VF6B



CR/CO/ZL/TS/NL/NS/IS/RS/DS/US

---

### Link Q bassa

Piero Lissoni

H209V6B

H209VF6B



CR/CO/NP/BP/ZL/TS/NL/NS/IS/RS/DS/US

---

### Link Q ADA bassa

Piero Lissoni

H208V6B

H208VF6B

NEW



CR/CO/NP/ZL/TS/NL/NS/IS/RS/DS/US

## Space Q bassa

Studio Olivari

H202V6B

H202VF6B



CR/CO/NP/BP/ZL/TS/NL/NS/IS/RS/DS/US

---

## Space Q ADA bassa

Studio Olivari

H201V6B

H201VF6B

NEW



CR/CO/NP/ZL/TS/NL/NS/IS/RS/DS/US

---

## Verona Q bassa

Studio Olivari

H117V6B

H117VF6B



CR/CO/NP/ZL/TS/NL/NS/IS/RS/DS/US

## Chiavistelli per porte interne - Latches for internal doors

### Link bassa

Piero Lissoni

H200V6B

H200VF6B



CR/CO/NP/BP/ZL/TS/NL/NS/IS/RS/DS/US

---

### Link ADA bassa

Piero Lissoni

H197V6B

H197VF6B

NEW



CR/CO/NP/ZL/TS/NL/NS/IS/RS/DS/US

---

### Space bassa

Studio Olivari

H193V6B

H193VF6B



CR/CO/NP/BP/ZL/TS/NL/NS/IS/RS/DS/US

## Space ADA bassa

Studio Olivari

H191V6B

H191VF6B

NEW



CR/CO/NP/ZL/TS/NL/NS/IS/RS/DS/US

---

## Verona V bassa

Studio Olivari

H106V6B

H109V6B



CR/CO/NP/ZL/TS/NL/NS/IS/RS/DS/US

---

## Alexandra

F.A. Porsche

H150-6



CR/CO/IS

## Chiavistelli per porte interne - Latches for internal doors

### Cubo S

Studio Olivari  
H135B6

CR/CO/NP/BP/ZL/TS/NL/NS/IS/RS/DS/US



### Link S

Piero Lissoni  
H199B6

CR/CO/NP/BP/ZL/TS/NL/NS/IS/RS/DS/US



### Link ADA S

Piero Lissoni  
H196B6

CR/CO/NP/BP/ZL/TS/NL/NS/IS/RS/DS/US



### Space S

Studio Olivari  
H192B6

CR/CO/NP/BP/ZL/TS/NL/NS/IS/RS/DS/US



### Space ADA S

Studio Olivari  
H190B6

CR/CO/NP/BP/ZL/TS/NL/NS/IS/RS/DS/US



### Verona S

Studio Olivari  
H105B6

CR/CO/NP/BP/ZL/TS/NL/NS/IS/RS/DS/US





Mezzi chiavistelli  
per porte hotel

Half latches  
for hotel doors

## Cubo

Studio Olivari  
I136

CR/CO/ZL/NL/NS/IS/RS/DS/US



## Link Q

Piero Lissoni  
I209

CR/CO/ZL/NL/NS/IS/RS/DS/US



## Link Q ADA

Piero Lissoni  
I208

CR/CO/ZL/NL/NS/IS/RS/DS/US



NEW

## Space Q

Studio Olivari  
I202

CR/CO/ZL/NL/NS/IS/RS/DS/US



## Space Q ADA

Studio Olivari  
I201

CR/CO/ZL/NL/NS/IS/RS/DS/US



NEW

## Verona Q

Studio Olivari  
I117

CR/CO/ZL/NL/NS/IS/RS/DS/US



## Link

Piero Lissoni  
I200

CR/CO/ZL/TS/NL/NS/IS/RS/DS/US

---



## Link ADA

Piero Lissoni  
I197

CR/CO/ZL/TS/NL/NS/IS/RS/DS/US

---



NEW

## Space

Studio Olivari  
I193

CR/CO/ZL/TS/NL/NS/IS/RS/DS/US

---



## Space ADA

Studio Olivari  
I191

CR/CO/ZL/TS/NL/NS/IS/RS/DS/US

---



NEW

## Verona V

Studio Olivari  
I106

CR/CO/ZL/TS/NL/NS/IS/RS/DS/US

---



## Mezzi chiavistelli per porte hotel - Half latches for hotel doors

### Cubo bassa

Studio Olivari

I136B

CR/CO/ZL/TS/NL/NS/IS/RS/DS/US



### Link Q bassa

Piero Lissoni

I209B

CR/CO/NP/BP/ZL/TS/NL/NS/IS/RS/DS/US



### Link Q ADA bassa

Piero Lissoni

I208B

CR/CO/NP/ZL/TS/NL/NS/IS/RS/DS/US



NEW

### Space Q bassa

Studio Olivari

I202B

CR/CO/NP/BP/ZL/TS/NL/NS/IS/RS/DS/US



### Space Q ADA bassa

Studio Olivari

I201B

CR/CO/NP/ZL/TS/NL/NS/IS/RS/DS/US



NEW

### Verona Q bassa

Studio Olivari

I117B

CR/CO/NP/ZL/TS/NL/NS/IS/RS/DS/US



## Mezzi chiavistelli per porte hotel - Half latches for hotel doors

### Link bassa

Piero Lissoni

I200B

CR/CO/NP/BP/ZL/TS/NL/NS/IS/RS/DS/US



### Link ADA bassa

Piero Lissoni

I197B

CR/CO/NP/ZL/TS/NL/NS/IS/RS/DS/US



NEW

### Space bassa

Studio Olivari

I193B

CR/CO/NP/BP/ZL/TS/NL/NS/IS/RS/DS/US



### Space ADA bassa

Studio Olivari

I191B

CR/CO/NP/ZL/TS/NL/NS/IS/RS/DS/US



NEW

### Verona V bassa

Studio Olivari

I106B

CR/CO/NP/ZL/TS/NL/NS/IS/RS/DS/US





Maniglie  
incasso

Flush  
handles

## Maniglie incasso - Flush handles

### Giotto Q

Studio Olivari  
D127



CR/CA/CO/NP/BP/ZL/ZT/TS/NL/NS/IS/RS/DS/US

---

### Giotto Q

Studio Olivari  
D128



CR/CA/CO/NP/BP/ZL/ZT/TS/NL/NS/IS/RS/DS/US



# Giotto Q

Studio Olivari  
D129



CR/CA/CO/NP/BP/ZL/ZT/TS/NL/NS/IS/RS/DS/US

---

# Giotto Q

Studio Olivari  
D130



CR/CA/CO/ZL/ZT/TS/NL/NS/IS/RS/DS/US

## Maniglie incasso - Flush handles

# Giotto

Nicola Novelletto

D122



CR/CA/CO/ZL/NS/IS

---

# Giotto

Nicola Novelletto

D123



CR/CA/CO/ZL/NS/IS

# Giotto

Nicola Novelletto

D124



CR/CA/CO/ZL/NS/IS

---

# Giotto

Nicola Novelletto

D125



CR/CA/CO/ZL/NS/IS

## Maniglie incasso - Flush handles

# Dante

Studio Olivari

D132



CR/CA/CO/NP/BP/ZL/ZT/TS/NL/NS/IS/RS/DS/US

---

# Dante

Studio Olivari

D133



CR/CA/CO/NP/BP/ZL/ZT/TS/NL/NS/IS/RS/DS/US

# Dante

Studio Olivari  
D134



CR/CA/CO/NP/BP/ZL/ZT/TS/NL/NS/IS/RS/DS/US

---

# Dante

Studio Olivari  
D135



CR/CA/CO/ZL/ZT/TS/NL/NS/IS/RS/DS/US

## Maniglie incasso - Flush handles

### Siro

Studio Olivari

D111  
D111F



CR/CO/NP/BP/ZL/TS/NL/NS/IS/RS/DS/US  
CR/CO/ZL/NS/IS

---

### Vico

Studio Olivari

D109  
D109F



CR/CO/NP/BP/ZL/TS/NL/NS/IS/RS/DS/US  
CR/CO/ZL/TS/NS/IS

# Maniglioni

## Pull handles

## Maniglioni - Pull handles

### Bios

Franco Sargiani

L205R: 285mm

L204R: 200mm

CR/CO/NL/IS/RS/DS

### Bios

Franco Sargiani

L205: 285mm

L204: 200mm

CR/CO/NL/IS/RS/DS

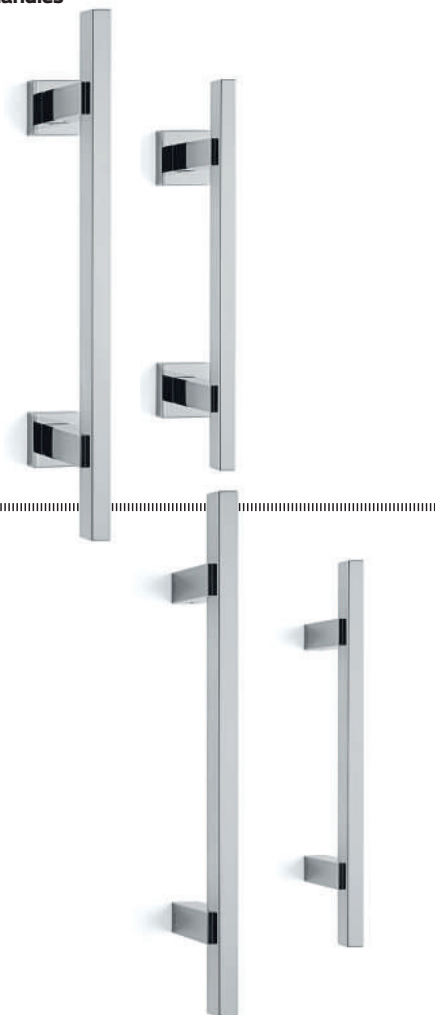



# Diana

Studio Olivari

L206R: 300mm

L207R: 300mm

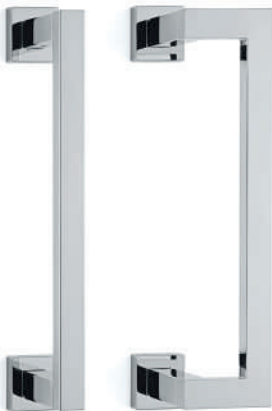

CR/CO/NP/BP/NL/IS/RS/DS/US

CR/CO/NL/IS/RS/DS/US

---

# Diana

Studio Olivari

L206: 300mm

L207: 300mm

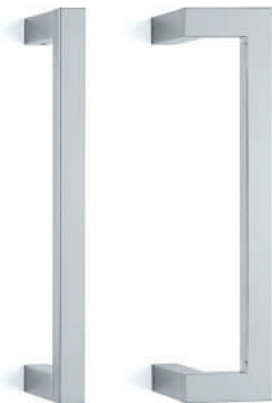

CR/CO/NP/BP/NL/IS/RS/DS/US

CR/CO/NL/IS/RS/DS/US

## Maniglioni - Pull handles

### Link

Piero Lissoni

L199R: 300mm

L200R: 300mm



CR/CO/NP/BP/NL/IS/RS/DS/US  
CR/CO/NL/IS/RS/DS/US

---

### Link

Piero Lissoni

L199: 300mm

L200: 300mm



CR/CO/NP/BP/NL/IS/RS/DS/US  
CR/CO/NL/IS/RS/DS/US

# Stilo

Enzo Mari

L190L: 285mm

L190M: 200mm

L189: 135mm

CR/CO/NL/IS/RS/DS

# Stilo

Enzo Mari

L191L: 285mm

L191M: 200mm

CR/CO/IS



## Maniglioni - Pull handles

# Planet Q

Studio Olivari

L203R: 160mm



CR/CA/CO/ZL/NL/NS/IS/RS/DS/US

---

# Planet

Studio Olivari

L195R: 160mm



CR/CA/CO/ZL/NL/NS/IS/RS/DS/US

# Planet

Studio Olivari

L195: 160mm

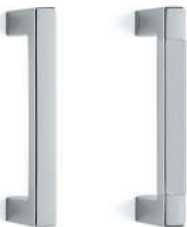

CR/CA/CO/ZL/NL/NS/IS/RS/DS/US

---

# Edison

Sergio Mazza,  
Giuliana Gramigna

L147R: 200mm

L147: 200mm



CR/CO/ZL/IS

## Maniglioni - Pull handles

### Alexandra

F.A. Porsche

L150: 250mm

L151: 250mm

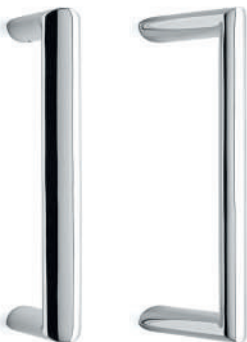

CR/CO/IS

### Aster

Studio Olivari

L174R: 250mm

L175R: 250mm



CA/ZT

Maniglioni  
alzanti

Pull lift up  
handles

## Maniglioni alzanti - Pull lift up handles

### Planet Q

Studio Olivari  
L121



### Planet Q corto

Studio Olivari  
L123



CR/CO/NP/BP/ZL/TS/NL/NS/IS/RS/DS/US

CR/CO/ZL/NS/IS/US



# Planet

Studio Olivari  
L111



# Planet corto

Studio Olivari  
L113



CR/CO/NP/BP/ZL/TS/NL/NS/IS/RS/DS/US

CR/CO/ZL/NS/IS/US

## Maniglioni alzanti - Pull lift up handles

### Polo

Studio Olivari  
L101



### Polo corto

Studio Olivari  
L103



CR/CO/ZL/TS/NL/NS/IS/RS/DS

CR/CO/ZL/IS

# Beta

Joe Colombo

L131



CR/CO/IS

## Maniglioni alzanti - Pull lift up handles

### Lotus Q

Javier Lopez  
L221



### Lotus

Javier Lopez  
L211



CR/CO/NP/BP/ZL/TS/NL/NS/IS/RS/DS/US

CR/CO/NP/BP/ZL/TS/NL/NS/IS/RS/DS/US

## Maniglioni alzanti - Pull lift up handles

### Lama

Gio Ponti  
L136



### Link

Piero Lissoni  
L126



CR/CO/BP/NP/ZL/TS/NL/NS/IS/RS/DS/US

CR/CO/BP/NP/ZL/TS/NL/NS/IS/RS/DS/US



Fermaporte  
Door stoppers

## Fermaporte - Door stoppers

### Cubo

Studio Olivari

B136

CR/CO/NP/BP/ZL/TS/NL/NS/IS/RS/DS/US



### Victor

Studio Olivari

B106

CR/CO/NP/BP/ZL/TS/NL/NS/IS/RS/DS/US



### Raffaella

Studio Olivari

B102

CR/CO/NP/BP/ZL/TS/NL/NS/IS/RS/DS/US



### Sector

Studio Olivari

B101

CR/CO/ZL/TS/NL/NS/IS/RS/DS



### Gardena

Studio Olivari

B103

ZL



### Stilo

Studio Olivari

B121

B123

CR/CO/NP/ZL  
CR/CO/NP/BP/ZL

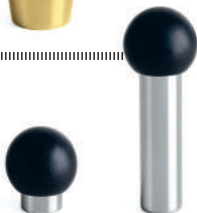



Componenti  
per porte  
blindate

Components  
for armored  
doors

NEW

# Cubo

Studio Olivari



I136RLR8B

per limitatore a rotazione / for rotation limiter  
CR/CO/ZL/TS/NL/NS/IS/RS/DS/US



I136RLSB

per limitatore a scorrimento / for sliding limiter  
CR/CO/ZL/TS/NL/NS/IS/RS/DS/US



I136RCLB

per cilindro codolo lungo / for cylinder long tang  
CR/CO/ZL/TS/NL/NS/IS/RS/DS/US



I136RCCB

per cilindro codolo corto / for cylinder short tang  
CR/CO/ZL/TS/NL/NS/IS/RS/DS/US



I136BCLB

per cilindro codolo lungo / for cylinder long tang  
CR/CO/ZL/TS/NL/NS/IS/RS/DS/US



I136BCCB

per cilindro codolo corto / for cylinder short tang  
CR/CO/ZL/TS/NL/NS/IS/RS/DS/US

## Mezzi chiavelessi porte blindate - Half latches for armored doors

### Link Q

Piero Lissoni



I209RLR8B

per limitatore a rotazione/*for rotation limiter*  
CR/CO/NP/BP/ZL/TS/NL/NS/IS/RS/DS/US



I209RLSB

per limitatore a scorrimento/*for sliding limiter*  
CR/CO/NP/BP/ZL/TS/NL/NS/IS/RS/DS/US



I209RCLB

per cilindro codolo lungo/*for cylinder long tang*  
CR/CO/NP/BP/ZL/TS/NL/NS/IS/RS/DS/US



I209RCCB

per cilindro codolo corto/*for cylinder short tang*  
CR/CO/NP/BP/ZL/TS/NL/NS/IS/RS/DS/US



I209BCLB

per cilindro codolo lungo/*for cylinder long tang*  
CR/CO/NP/BP/ZL/TS/NL/NS/IS/RS/DS/US



I209BCCB

per cilindro codolo corto/*for cylinder short tang*  
CR/CO/NP/BP/ZL/TS/NL/NS/IS/RS/DS/US

# Space Q

Studio Olivari



**I202RLR8B**

per limitatore a rotazione/*for rotation limiter*  
CR/CO/NP/BP/ZL/TS/NL/NS/IS/RS/DS/US



**I202RLSB**

per limitatore a scorrimento/*for sliding limiter*  
CR/CO/NP/BP/ZL/TS/NL/NS/IS/RS/DS/US



**I202RCLB**

per cilindro codolo lungo/*for cylinder long tang*  
CR/CO/NP/BP/ZL/TS/NL/NS/IS/RS/DS/US



**I202RCCB**

per cilindro codolo corto/*for cylinder short tang*  
CR/CO/NP/BP/ZL/TS/NL/NS/IS/RS/DS/US



**I202BCLB**

per cilindro codolo lungo/*for cylinder long tang*  
CR/CO/NP/BP/ZL/TS/NL/NS/IS/RS/DS/US



**I202BCCB**

per cilindro codolo corto/*for cylinder short tang*  
CR/CO/NP/BP/ZL/TS/NL/NS/IS/RS/DS/US

# Verona Q

Studio Olivari



I117RLR8B  
per limitatore a rotazione/*for rotation limiter*  
CR/CO/NP/ZL/TS/NL/NS/IS/RS/DS/US



I117RLSB  
per limitatore a scorrimento/*for sliding limiter*  
CR/CO/NP/ZL/TS/NL/NS/IS/RS/DS/US



I117RCLB  
per cilindro codolo lungo/*for cylinder long tang*  
CR/CO/NP/ZL/TS/NL/NS/IS/RS/DS/US



I117RCCB  
per cilindro codolo corto/*for cylinder short tang*  
CR/CO/NP/ZL/TS/NL/NS/IS/RS/DS/US



I117BCLB  
per cilindro codolo lungo/*for cylinder long tang*  
CR/CO/NP/ZL/TS/NL/NS/IS/RS/DS/US



I117BCCB  
per cilindro codolo corto/*for cylinder short tang*  
CR/CO/NP/ZL/TS/NL/NS/IS/RS/DS/US

# Link

Piero Lissoni



**I200RLR8B**

per limitatore a rotazione/*for rotation limiter*  
CR/CO/NP/BP/ZL/TS/NL/NS/IS/RS/DS/US



**I200RLSB**

per limitatore a scorrimento/*for sliding limiter*  
CR/CO/NP/BP/ZL/TS/NL/NS/IS/RS/DS/US



**I200RCLB**

per cilindro codolo lungo/*for cylinder long tang*  
CR/CO/NP/BP/ZL/TS/NL/NS/IS/RS/DS/US



**I200RCCB**

per cilindro codolo corto/*for cylinder short tang*  
CR/CO/NP/BP/ZL/TS/NL/NS/IS/RS/DS/US



**I200BCLB**

per cilindro codolo lungo/*for cylinder long tang*  
CR/CO/NP/BP/ZL/TS/NL/NS/IS/RS/DS/US



**I200BCCB**

per cilindro codolo corto/*for cylinder short tang*  
CR/CO/NP/BP/ZL/TS/NL/NS/IS/RS/DS/US

## Mezzi chiavistelli porte blindate - Half latches for armored doors

# Space

Piero Lissoni



**I193RLR8B**

per limitatore a rotazione/*for rotation limiter*  
CR/CO/NP/BP/ZL/TS/NL/NS/IS/RS/DS/US



**I193RLSB**

per limitatore a scorrimento/*for sliding limiter*  
CR/CO/NP/BP/ZL/TS/NL/NS/IS/RS/DS/US



**I193RCLB**

per cilindro codolo lungo/*for cylinder long tang*  
CR/CO/NP/BP/ZL/TS/NL/NS/IS/RS/DS/US



**I193RCCB**

per cilindro codolo corto/*for cylinder short tang*  
CR/CO/NP/BP/ZL/TS/NL/NS/IS/RS/DS/US



**I193BCLB**

per cilindro codolo lungo/*for cylinder long tang*  
CR/CO/NP/BP/ZL/TS/NL/NS/IS/RS/DS/US



**I193BCCB**

per cilindro codolo corto/*for cylinder short tang*  
CR/CO/NP/BP/ZL/TS/NL/NS/IS/RS/DS/US

# Verona V

Studio Olivari



I106RLR8B

per limitatore a rotazione/*for rotation limiter*  
CR/CO/NP/ZL/TS/NL/NS/IS/RS/DS/US



I106RLSB

per limitatore a scorrimento/*for sliding limiter*  
CR/CO/NP/ZL/TS/NL/NS/IS/RS/DS/US



I106RCLB

per cilindro codolo lungo/*for cylinder long tang*  
CR/CO/NP/ZL/TS/NL/NS/IS/RS/DS/US



I106RCCB

per cilindro codolo corto/*for cylinder short tang*  
CR/CO/NP/ZL/TS/NL/NS/IS/RS/DS/US



I106BCLB

per cilindro codolo lungo/*for cylinder long tang*  
CR/CO/NP/ZL/TS/NL/NS/IS/RS/DS/US



I106BCCB

per cilindro codolo corto/*for cylinder short tang*  
CR/CO/NP/ZL/TS/NL/NS/IS/RS/DS/US



### Cubo

Studio Olivari

I136F

con foro codolo/[with tang hole](#)

CR/CO/NP/BP/ZL/TS/NL/NS/IS/RS/DS/US

---



### Link

Piero Lissoni

I200F

con foro codolo/[with tang hole](#)

CR/CO/NP/BP/ZL/TS/NL/NS/IS/RS/DS/US

---



### Space

Studio Olivari

I193F

con foro codolo/[with tang hole](#)

CR/CO/NP/BP/ZL/TS/NL/NS/IS/RS/DS/US

---



### Verona

Studio Olivari

I106F

con foro codolo/[with tang hole](#)

CR/CO/NP/ZL/TS/NL/NS/IS/RS/DS/US

---



# Defender

Studio Olivari



1611B  
foro  $\varnothing 46 / \varnothing 46$  hole  
CR/CO/NP/BP/ZL/TS/NL/NS/IS/RS/DS/US



1612B  
foro  $\varnothing 50 / \varnothing 50$  hole  
CR/CO/NP/BP/ZL/TS/NL/NS/IS/RS/DS/US



1601B  
foro  $\varnothing 46 / \varnothing 46$  hole  
CR/CO/NP/BP/ZL/TS/NL/NS/IS/RS/DS/US



1602B  
foro  $\varnothing 50 / \varnothing 50$  hole  
CR/CO/NP/BP/ZL/TS/NL/NS/IS/RS/DS/US

# Yale

Studio Olivari



1522B

foro yale/profile cylinder hole

CR/CO/NP/BP/ZL/TS/NL/NS/IS/RS/DS/US



1613B

foro yale/profile cylinder hole

CR/CO/NP/BP/ZL/TS/NL/NS/IS/RS/DS/US



1502B

foro yale/profile cylinder hole

CR/CO/NP/BP/ZL/TS/NL/NS/IS/RS/DS/US



1603B

foro yale/profile cylinder hole

CR/CO/NP/BP/ZL/TS/NL/NS/IS/RS/DS/US



Nylon

Nylon

Nylon

# Boma

Monti G.P.A.

M501



■ NE ■ BI ■ GR

---

# Iseo

Sergio Asti

M507



■ NE ■ BI

# Chiara

Studio Olivari

M509



■ NE ■ BI



Nylon

# Gamma

Studio Olivari

P506



NE/BI

# Boma

Studio Olivari

L501



NE/BI/GR



# Venezia

Studio Olivari

H506-6



NE/BI

---

# Nemi

Studio Olivari

D509



NE/BI

Il catalogo è soggetto ad aggiornamenti.

Dati, misure o schemi hanno solamente carattere informativo e non sono vincolanti.

Eventuali errori e/o refusi di stampa non costituiscono motivo di contestazione.

Ci riserviamo di apportare qualsiasi modifica ai prodotti e di eliminarli dalla produzione, senza obbligo di preavviso.

Modelli e marchi depositati. Tutti i diritti riservati © OLIVARI B. s.p.a.

I prodotti OLIVARI sono tutelati da brevetto in Europa e in molti paesi extra UE.

Al fine di evitare contraffazioni, marchiamo al laser tutte le maniglie sia con il logo OLIVARI sulla leva che con il codice identificativo del lotto e la data di produzione sul collarino. Questa marcatura indelebile, certifica che il prodotto è realizzato in ambito ISO 9001 e ne consente la tracciabilità. Invitiamo i clienti a diffidare da prodotti "tipo OLIVARI" e ad acquistare solo prodotti originali "OLIVARI".

We reserve the right to modify and discontinue any products, without prior notice. Data sheets, measurements or patterns are only for information and are not binding. Any misprints do not allow raise objections. Registered trademarks and patented designs. All rights reserved © Olivari B. s.p.a. OLIVARI products are registered and patented in Europe and many countries extra UE.

In order to avoid counterfeits, we laser-mark all the door handles both with the OLIVARI logo on the lever and with the identification code of the lot and the date of production on the neck. This indelible marking, certifies that the product is made in ISO 9001 and allows traceability. We invite customers to beware of "OLIVARI type" products and to buy only "OLIVARI" original products.



## Concept and graphic

Marco Strina

## Still life

Andrea Andreini

## Printed in Italy

05.2022

## OLIVARI B. spa

Via Giacomo Matteotti, 140

28021 Borgomanero NO Italy

T +39 0322 835080

olivari@olivari.it

www.olivari.it





olivari.it